

Singleturn absolute encoder FVS58

- Industrial standard housing Ø58 mm
- 13 Bit singleturn
- Output code: gray and binary
- Short-circuit proof push-pull output
- Inputs for selecting counting direction, LATCH, and PRESET
- Code change frequency up to 400 kHz
- Servo or clamping flange

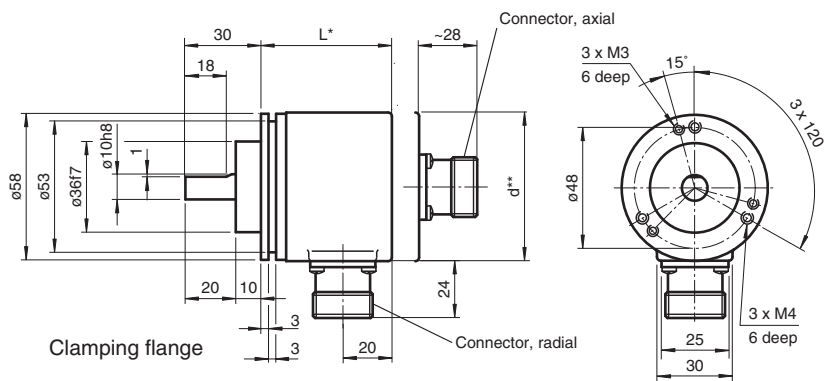

Dimensions



* with axial exit position L = 42/53 (aluminum/stainless steel),
with radial exit position L = 53
** Aluminium: d = 59, stainless steel: d = 61

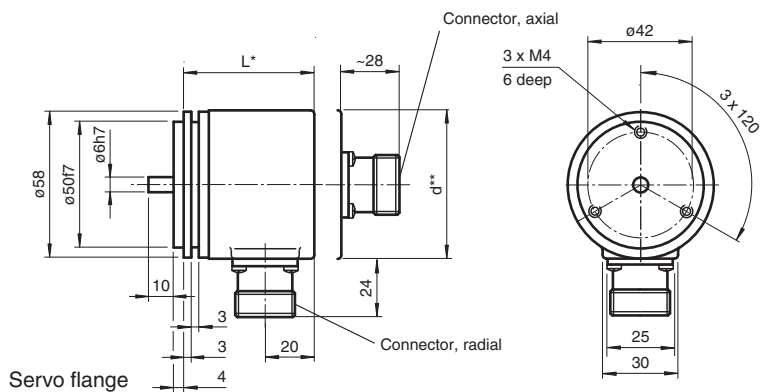

* with axial exit position L = 42/53 (aluminum/stainless steel),
with radial exit position L = 53
** Aluminium: d = 59, stainless steel: d = 61

Dimensions

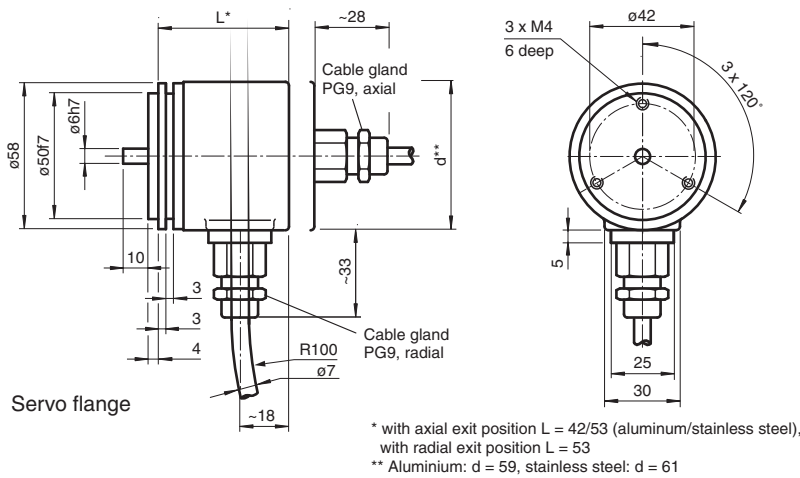
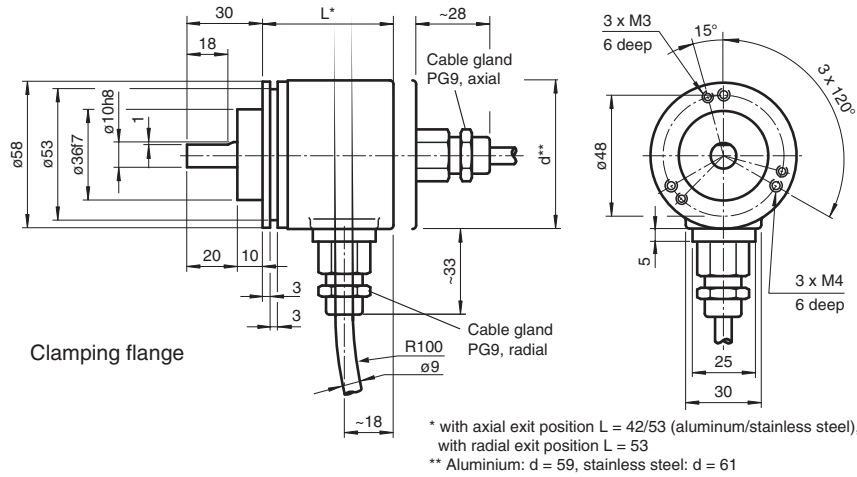

Technical Data

Electrical specifications		
Operating voltage	U_B	10 ... 30 V DC
No-load supply current	I_0	max. 140 mA
Power consumption	P_0	$\leq 2 W$, without output drivers
Linearity		± 0.5 LSB
Output code		Gray code, binary code and Gray excess code
Code course (counting direction)		cw ascending (clockwise rotation, code course ascending)
Code preparation time		0.3 ms
Interface		
Interface type		Push-pull, parallel , short-circuit protected
Resolution		
Single turn		13 Bit
Load current		40 mA
Voltage drop		≤ 2.5 V
Signal voltage		
High		operating voltage minus voltage drop
Low		≤ 2.8 V
Rise time		300 ns
De-energized delay		300 ns
Code change frequency		400 kHz
Input 1		
Input type		Selection of counting direction (cw/ccw)

Release date: 2023-02-14 Date of issue: 2023-02-14 Filename: t25102_eng.pdf



















Technical Data

Signal voltage		
High		10 ... 30 V
Low		0 ... 2 V
Input current		< 6 mA
Signal duration		min. 10 ms
Switch-on delay		≥ 1 ms
Switch-off delay		≥ 1 ms
Input 2		
Input type		Temporary storage (LATCH)
Signal voltage		
High		10 ... 30 V
Low		0 ... 2 V
Input current		< 6 mA
Signal duration		min. 100 µs
Switch-on delay		< 0.1 ms
Switch-off delay		< 0.1 ms
Input 3		
Input type		zero-set (PRESET)
Signal voltage		
High		10 ... 30 V
Low		0 ... 2 V
Input current		< 6 mA
Signal duration		min. 10 ms
Switch-on delay		< 1 ms
Connection		
Connector		type 9424 (M23), 19-pin
Cable		Ø9 mm, 12 x 2 x 0.14 mm ² , 2 m
Standard conformity		
Degree of protection		DIN EN 60529, IP65
Climatic testing		DIN EN 60068-2-3, no moisture condensation
Emitted interference		EN 61000-6-4:2007
Noise immunity		EN 61000-6-2:2005
Shock resistance		DIN EN 60068-2-27, 100 g, 6 ms
Vibration resistance		DIN EN 60068-2-6, 10 g, 10 ... 2000 Hz
Approvals and certificates		
UL approval		cULus Listed, General Purpose, Class 2 Power Source
Ambient conditions		
Operating temperature		-40 ... 85 °C (-40 ... 185 °F) cable models: -30 ... 70 °C (rigid wiring) -5 ... 70 °C (flexible wiring)
Storage temperature		-40 ... 85 °C (-40 ... 185 °F) (cable models: -5 ... 70 °C)
Mechanical specifications		
Material		
Combination 1		housing: powder coated aluminum flange: aluminum shaft: stainless steel
Combination 2 (Inox)		housing: stainless steel flange: stainless steel shaft: stainless steel
Mass		approx. 200 g (combination 1) approx. 400 g (combination 2)
Rotational speed		max. 12000 min ⁻¹
Moment of inertia		30 gcm ²
Starting torque		≤ 5 Ncm
Shaft load		

Technical Data





Axial	40 N
Radial	110 N

Accessories

	9203	Angled flange
	9424	Female cordset
	9310-3	Synchro clamping element
	9300	Mounting bracket for servo flange
	KW-10/10	Helical coupling
	KW-6/10	Helical coupling
	KW-6/6	Helical coupling
	KW-6/8	Helical coupling
	9401 10*10	Spring steel coupling
	9401 10*12	Spring steel coupling
	9401 6*10	Spring steel coupling
	9401 6*6	Spring steel coupling
	9402 6*6	Spring steel coupling
	9404 10*10	Spring disk coupling
	9404 6*6	Spring disk coupling
	9409 10*10	Bellows coupling
	9409 6*10	Bellows coupling
	9409 6*6	Bellows coupling

Release date: 2023-02-14 Date of issue: 2023-02-14 Filename: t25102_eng.pdf

Accessories

	9409 6*8	Bellows coupling
	9410 10*10	Precision coupling
	9410 6*6	Precision coupling
	MBT-36ALS	Spring-loaded mounting bracket with a diameter of 36 mm

Function

The emphasis for this series is on rapid data transfer. Position data are read directly out of the Gray code disc. The high code switching frequency of 400 kHz is achieved by consciously avoiding the use of a microcontroller.

In terms of the mechanics, designs with clamping flange or servo flange are available for the FVS58 singleturn absolute encoder.

Connection

Signal	Cable Ø9 mm, 24-core	Connector 9424, 19-pin	Explanation
GND (rotary encoder)	White	6	Power supply
U _b (rotary encoder)	Brown	12	Power supply
Data bit 1	Green	1	Data output
Data bit 2	Yellow	2	Data output
Data bit 3	Grey	3	Data output
Data bit 4	Pink	4	Data output
Data bit 5	Blue	5	Data output
Data bit 6	Red	7	Data output
Data bit 7	Black	8	Data output
Data bit 8	Violet	9	Data output
Data bit 9	Grey/Pink	10	Data output
Data bit 10	Red/Blue	11	Data output
Data bit 11	White/Green	13	Data output
Data bit 12	Brown/Green	14	Data output
Data bit 13	White/Yellow	15	Data output
	White/Grey	-	Reserved
	Grey/Brown	19	Reserved
V/R	White/Pink	16	Input for selection of counting direction
LATCH	Pink/Brown	17	Temporary storage input
	White/Blue	-	Reserved
PRESET	Brown/Blue	18	Zero setting input
	White/Red	-	Reserved
	Brown/Red	-	Reserved

Interface

Inputs

Input for temporary storage (LATCH)
Input zero setting (PRESET)

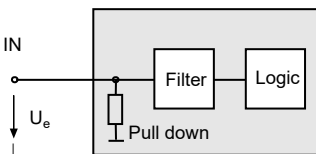

Input level: "0" 0 V ... 2 V,
"1" 10 V ... 30 V,
I_e < 6 mA

Input for selection of counting direction (V/R)

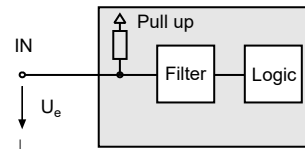

Input for selection of counting direction (V/R)

The counting direction for the absolute value rotary encoder as seen looking on the shaft is defined as right rotating (cw) rising or descending. The counting direction can be reversed with the V/R input. If the input is not used, the counting direction is defined as rising (standard), the level is at "1". Pulse duration T > 10 ms.

Input level: "1" or unused = rising code value with direction of rotation cw.

Input level: "0" = descending code value for direction of rotation cw.

Input for temporary storage (LATCH)

With LATCH input "active", the position data on the parallel interface are "frozen". This makes it possible to accept position data without errors (especially for binary position data), since any change in the data during the read procedure is prevented. If this input is unused, its value is "0". Pulse duration $T > 100 \mu s$.

Input level: "1" = position data saved and stable at the output.

Input level: "0" or unused = position data free running at the output.

Input zero setting (PRESET)

By means of the PRESET input, the absolute value rotary encoder can be adjusted electronically to position value 0. Pulse duration $T > 10 ms$.

Input level: "0" or unused = inactive.

Input level: "1" = Data output word is set to 0.

Type Code

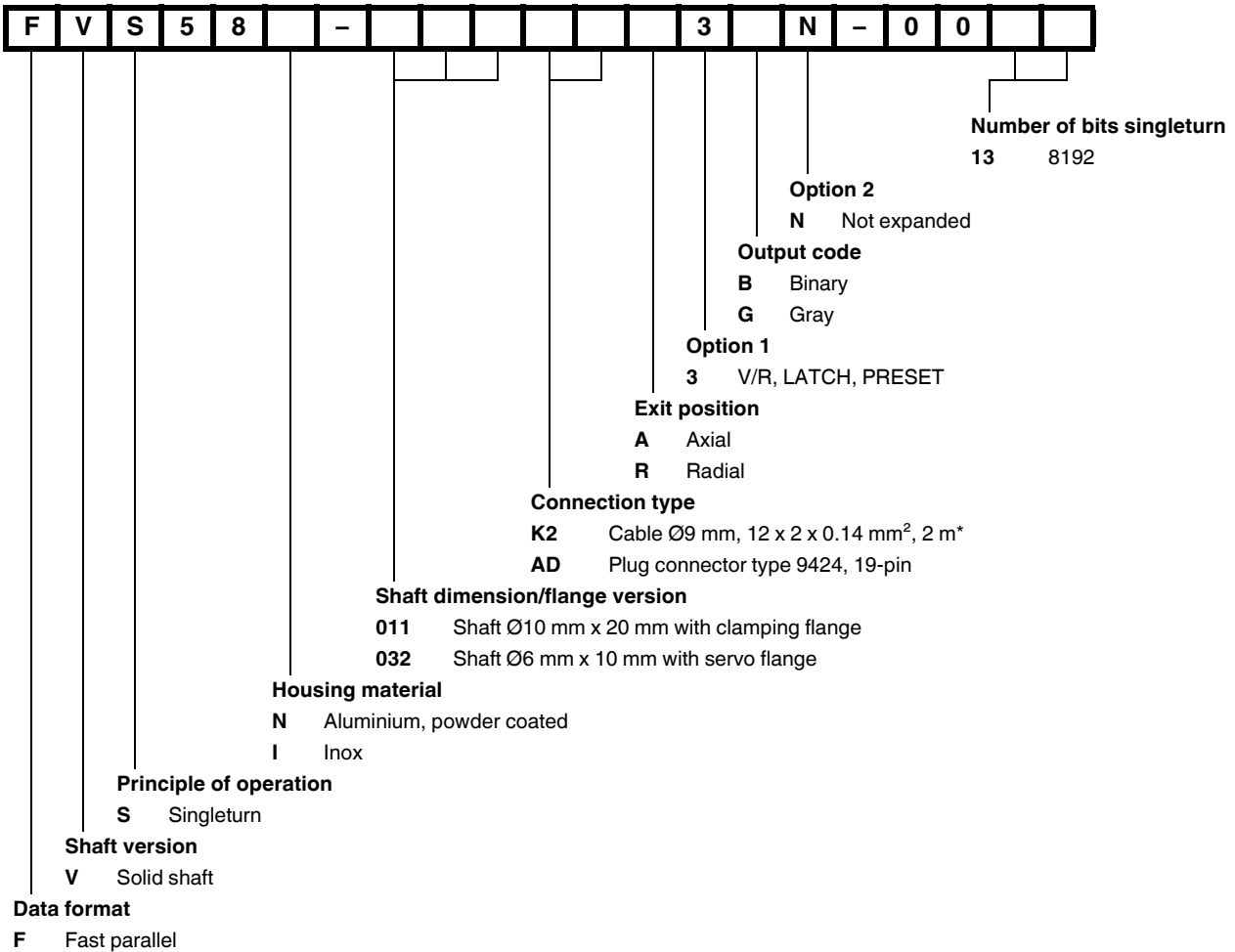

Release date: 2023-02-14 Date of issue: 2023-02-14 Filename: t25102_eng.pdf