

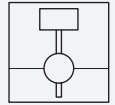

Magnetic Immersion Probe for Limit Value Detection



LML-Ex

- Sensor for limit value detection in liquids
- Media contacting parts of stainless steel
- Mounting without removing the float
- Approved for zone 0



Function

The device is a sensor for limit value detection in liquids. A ring magnet integrated in the float activates the contacts inside the probe tube via its magnetic field. If the probe strays outside the range of the mechanical contact, it reverts to the output status. The skipping of switching points caused by abrupt level changes can be avoided using snap-on set collars on the probe tube. The same set collars are also used for latching contact operation.

Connection

NO contact

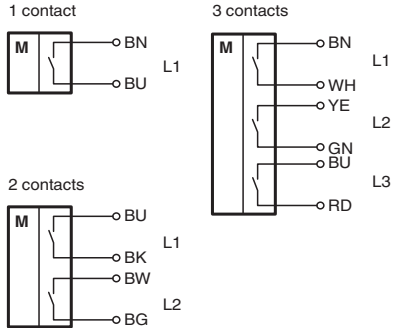

NC contact

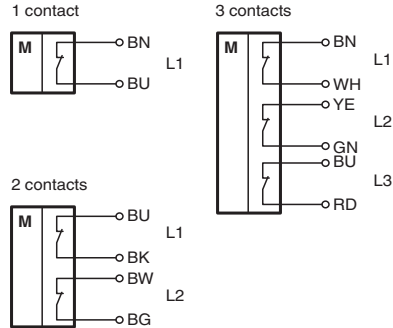

Change-over contact

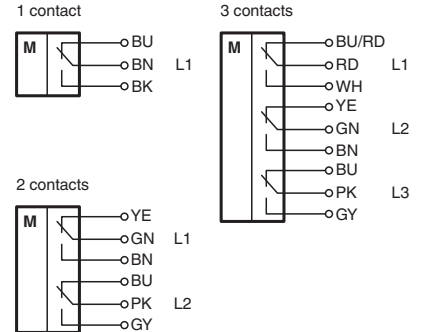

Release date: 2023-09-11 Date of issue: 2023-09-11 Filename: t3030_eng.pdf

Dimensions

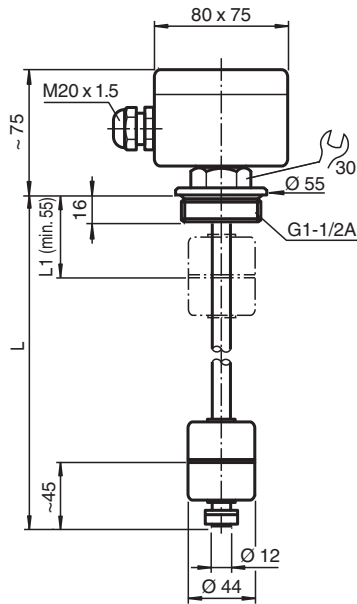

LML*S2-G5S-**-EX

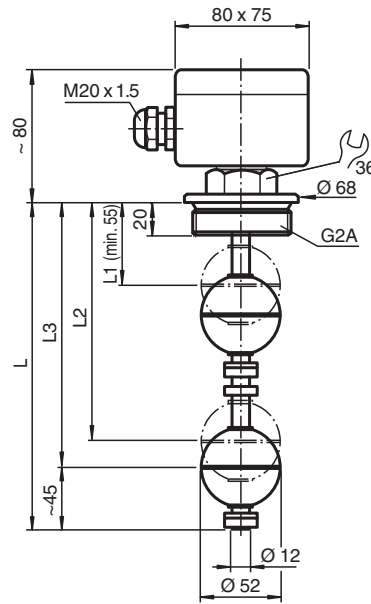

LML3S3-G6S-**-EX

Technical Data

General specifications

Function principle	ring magnet as switching element in the float, reed contact number of contacts: - version LML1: 1 contact - version LML2: 2 contacts - version LML3: 3 contacts switching function: - version DO: with rising level NC contact - version DS: with rising level NO contact - version DW: with rising level change-over contact
Equipment architecture	A measuring system consists of a magnet-operated immersion probe LML*S*-*S*-* Ex and a (up to 3) isolated amplifier(s) with certified intrinsically safe circuit, for example KFD2-SR2-Ex1.W.
Series	LML-Ex

Directive conformity

Electromagnetic compatibility	
Directive 2014/30/EU	EN 61000-6-2:2006 , EN 61000-6-4:2011

Conformity

Degree of protection	IEC 60529:2000
----------------------	----------------

Operating conditions

Installation conditions	
Switching point	position according to specification
Process conditions	
Process temperature	-30 ... 150 °C (-22 ... 302 °F)
Process pressure (static pressure)	≤ 25 bar (362.6 psi)
Density	version S2: ≥ 0.8 g/cm ³ version S3: ≥ 0.7 g/cm ³

Ambient conditions

Ambient temperature	terminal box: -50 ... 60 °C (-58 ... 140 °F)
---------------------	--

Mechanical specifications

Degree of protection	IP66 / IP68
Connection	terminal box, 6 terminals , max. 2.5 mm ²
Material	float, guide tube, process connection: stainless steel 1.4571/316Ti terminal box: aluminum die-casting

Technical Data

Dimensions		float: - version S2: cylinder Ø44 mm x 52 mm - version S3: ball Ø52 mm guide tube: Ø12 mm, max. length 3000 mm terminal box: 80 x 75 x 57 mm
Process connection		thread G1-1/2A, G2A to DIN/ISO 228/1
Data for application in connection with hazardous areas		
EU-type examination certificate		KEMA 03 ATEX 1496 X
Marking		⊕ II 1/2G EEx ia IIC T3...T6
Voltage	U _i	36 V
Current	I _i	100 mA
Internal capacitance	C _i	0 nF
Internal inductance	L _i	0 µH
Directive conformity		
Directive 2014/34/EU		EN 60079-0:2012, EN 60079-11:2012, EN 60079-26:2007
General information		
Supplementary information		Observe the certificates, declarations of conformity, instruction manuals, and manuals where applicable. For information see www.pepperl-fuchs.com .
Accessories		
Designation		- LML-Z11 set collar, 1.4571/316Ti - LML-FS2 float, cylinder, Ø44 mm x 52 mm, 1.4571/316Ti - LML-FS3 float, ball, Ø52 mm, 1.4571/316Ti

Type Code

This overview does not mark options which are mutually exclusive.

L	M	L	(1)	S	(2)	-	(3)	S	-	(4)	-	E	x	/	L
---	---	---	-----	---	-----	---	-----	---	---	-----	---	---	---	---	---

LML	Device
LML	Magnetic immersion probe for limit value detection

(1)	Number of contacts
1	1 contact
2	2 contacts
3	3 contacts

S	Guide tube material
S	Stainless steel 1.4571/316Ti

(2)	Float
2	Cylinder, Ø44 mm x 52 mm, stainless steel 1.4571/316Ti
3	Ball, Ø52 mm, stainless steel 1.4571/316Ti

(3)	Process connection
G5	Thread G1-1/2A, DIN/ISO 228/1
G6	Thread G2A, DIN/ISO 228/1

S	Process connection material
S	Stainless steel 1.4571/316Ti

(4)	Electrical output
DO	NC contact, directly
DS	NO contact, directly
DW	Change-over contact, directly

Ex	Approval
Ex	ATEX II 1/2G EEx ia IIC T6...T3

L	Guide tube length
Length	Specified length, max. 3000 mm Specify the location of the contacts when placing your order. The tube length L will be defined corresponding to the lowest contact location. - Minimum distance between L1 and L2: 20 mm If you are using 3 contacts, observe the following distances: - Minimum distance between L1 and L2: 80 mm - Minimum distance between L2 and L3: 20 mm