

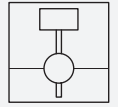

Magnetic Immersion Probe for Limit Value Detection



LML-P

- Sensor for limit value detection in liquids
- Media contacting parts of plastic
- Mounting without removing the float (G5 and G6)



Function

The device is a sensor for limit value detection in liquids.

A ring magnet integrated in the float activates the contacts inside the probe tube via its magnetic field. If the probe strays outside the range of the mechanical contact, it reverts to the output status.

The skipping of switching points caused by abrupt level changes can be avoided using snap-on set collars on the probe tube. The same set collars are also used for latching contact operation.

Connection

Change-over contact

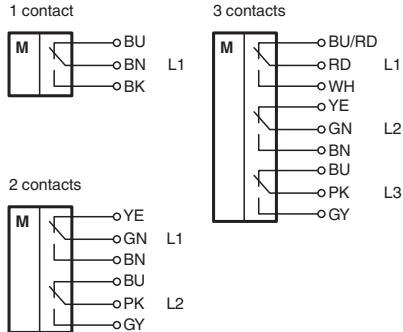

Dimensions

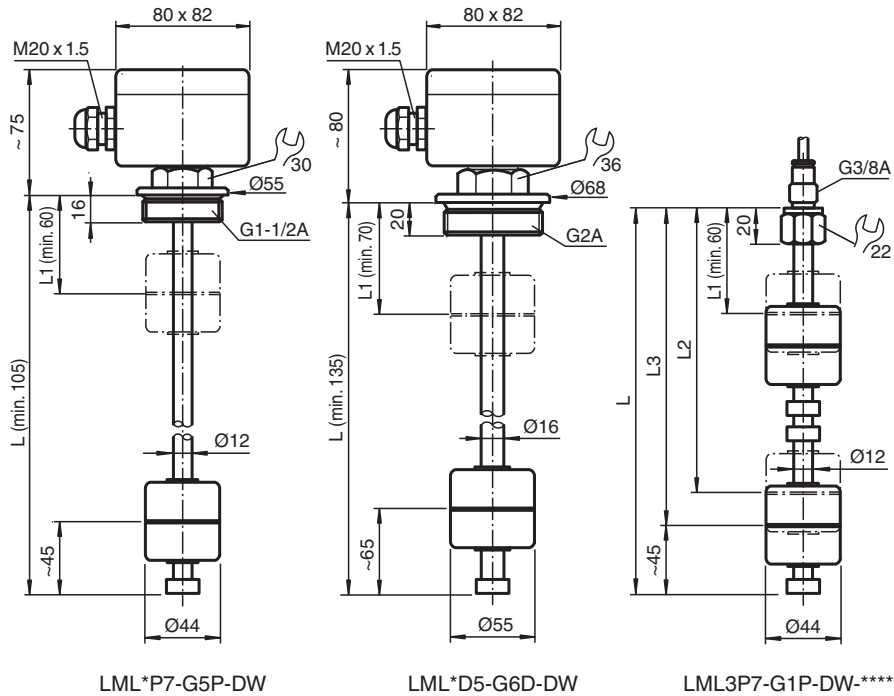

Technical Data

General specifications	
Function principle	ring magnet as switching element in the float, reed contact, change-over contact number of contacts: - version LML1: 1 contact - version LML2: 2 contacts - version LML3: 3 contacts
Series	LML-P
Supply	
Rated voltage	U_r 250 V AC/DC
Current consumption	1 A
Power consumption	40 VA
Output	
Connection	This device may be used with any sequential circuit, as long as the circuit can support the electrical circuit values of the switching elements.
Directive conformity	
Low voltage	
Directive 2014/35/EU	EN 61010-1:2010
Conformity	
Degree of protection	IEC 60529:2000
Operating conditions	
Installation conditions	
Switching point	position according to specification
Process conditions	
Process temperature	version PP: -10 ... 80 °C (14 ... 176 °F) version PVDF: -10 ... 100 °C (14 ... 212 °F)
Process pressure (static pressure)	≤ 3 bar (43.5 psi)
Density	≥ 0.8 g/cm ³
Ambient conditions	
Ambient temperature	-20 ... 70 °C (-4 ... 158 °F)
Mechanical specifications	
Degree of protection	IP66 / IP68

Release date: 2023-09-11 Date of issue: 2023-09-11 Filename: t3032_eng.pdf

Technical Data

Connection	version LML: terminal box, max. 9 terminals version LML-PVC1: connection cable 1 m (3.3 ft), 0.75 mm ²
Material	float, guide tube, process connection: - version PP: PP (Polypropylene) - version PVDF: PVDF (Polyvinylidenfluoride) connection cable: PVC terminal box: Polyester
Dimensions	float: - version PP: cylinder Ø44 mm x 44 mm - version PVDF: cylinder Ø55 mm x 70 mm guide tube: - version D: Ø12 mm, max. length 1000 mm - version P: Ø16 mm, max. length 1000 mm - other lengths on request terminal box: 80 x 82 x 55 mm
Process connection	thread G3/8A, G1-1/2A, G2A to DIN/ISO 228/1
General information	
Supplementary information	Observe the certificates, declarations of conformity, instruction manuals, and manuals where applicable. For information see www.pepperl-fuchs.com .
Accessories	
Designation	- LML-Z21 set collar, PP - LML-Z22 set collar, PVDF - LML-FD5 float, cylinder, Ø55 mm x 70 mm, PVDF - LML-FP7 float, cylinder, Ø44 mm x 44 mm, PP

Type Code

This overview does not mark options which are mutually exclusive.

L	M	L	(1)	(2)	(3)	-	(4)	(5)	-	D	W	-	P	V	C	1	/	L
---	---	---	-----	-----	-----	---	-----	-----	---	---	---	---	---	---	---	---	---	---

LML	Device
LML	Magnetic immersion probe for limit value detection

(1)	Number of contacts
1	1 contact
2	2 contacts
3	3 contacts

(2)	Guide tube material
D	Plastic PVDF, with G6 process connection
P	Plastic PP, with G1 or G5 process connection

(3)	Float
5	Cylinder, Ø55 mm x 70 mm, plastic PVDF
7	Cylinder, Ø44 mm x 44 mm, plastic PP

(4)	Process connection
G1	Thread G3/8, DIN/ISO 228/1, with PVC cable, 1 m
G5	Thread G1-1/2A, DIN/ISO 228/1
G6	Thread G2A, DIN/ISO 228/1

(5)	Process connection material
D	Plastic PVDF
P	Plastic PP

DW	Electrical output
DW	Change-over contact, directly

PVC1	Additional options
PVC1	PVC cable, 1 m, for G1 process connection

L	Guide tube length
Length	Specified length, max. 1000 mm, other lengths on request Specify the location of the contacts when placing your order. The tube length L will be defined corresponding to the lowest contact location. - Minimum distance between L1 and L2: 20 mm If you are using 3 contacts, observe the following distances: - Minimum distance between L1 and L2: 80 mm (for plastic PVDF: 100 mm) - Minimum distance between L2 and L3: 20 mm