

Com Unit for MODBUS RTU

FB8207*



- Interface between the I/O modules and the PCS/PLC
- Com unit for 80 analog or 184 digital channels
- Communication via MODBUS RTU
- Installation in suitable enclosures in Zone 1
- Module can be exchanged under voltage (hot swap)
- HART communication via service bus
- Configuration via FDT 1.2 DTM
- Non-volatile memory for configuration and parameter settings
- Self configuration in redundant systems
- Permanently self-monitoring
- Outputs drive to safe state in case of failures

Com Unit for MODBUS RTU



Function

The MODBUS RTU com unit forms the interface between the I/O modules on the backplane and the process control system. It supports all single width and dual width I/O modules. Thereby signals from NAMUR sensors, mechanical contacts, high-power solenoid drivers, power relays, sounders, and alarm LEDs are transported to the higher-level bus system. The com unit can be easily configured via DTM and supports redundancy as well as HART.

Connection

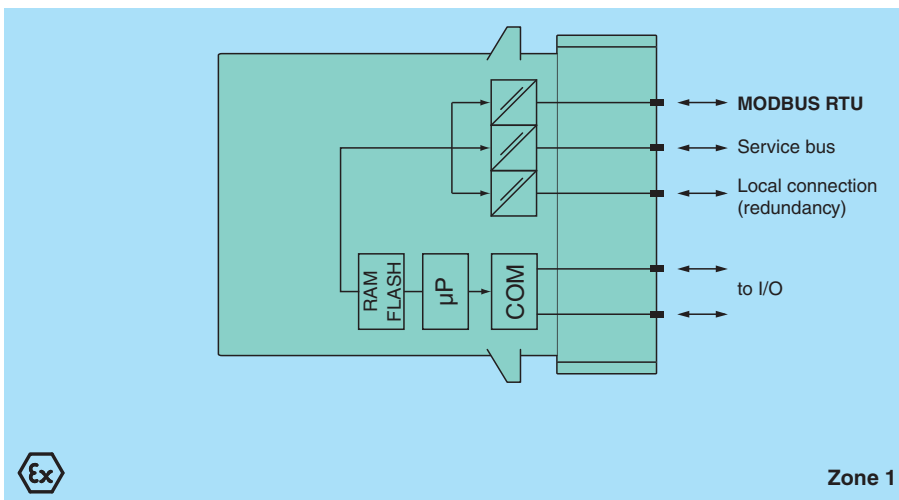

Technical Data

Supply	
Connection	backplane bus
Rated voltage	U _r 5 V DC , only in connection with the power supplies FB92**
Power consumption	2 W
Fieldbus interface	
Fieldbus type	MODBUS RTU
MODBUS RTU	
Connection	wired to Ex e terminals via backplane
Baud rate	max. 38.4 kBit/s

Release date: 2020-04-30 Date of issue: 2020-04-30 Filename: t41360_eng.pdf

Technical Data

Number of stations per bus line	max. 245 (MODBUS), max. 119 (service bus)
Number of channels per station	max. 80 analog, max. 184 digital (standard configuration)
Number of stations per bus segment	max. 31 (RS-485 standard)
Number of repeaters between Master and Slave	max. 3
Supported I/O modules	all FB remote I/O modules
Bus length	max. 1200 m (FOL, 38.4 kBd), max. 1200 m (copper cable, 38.4 kBd)
FOL (fiber optic link)	additional hardware required
Addressing	via configuration software
MODBUS address	standard compliant (factory standard setting: 126)
Service bus address	max. 119 , redundancy address = base + 128 (automatic)
HART communication	via service bus
Redundancy	system dependent
Internal bus	
Connection	backplane bus
Redundancy	via front connector
Indicators/settings	
LED indicator	LED green (power supply): On = operating, fast flash = cold start LED red (collective alarm): On = internal fault, flashing = no Modbus RTU connection LED yellow (operating mode): flashing 1 (1:1 ratio) = active, normal operation; flashing 2 (7:1 ratio) = active, simulation
Directive conformity	
Electromagnetic compatibility	
Directive 2014/30/EU	EN 61326-1
Conformity	
Electromagnetic compatibility	NE 21
Degree of protection	IEC 60529
Fieldbus standard	IEC 61158-2
Environmental test	EN 60068-2-14
Shock resistance	EN 60068-2-27
Vibration resistance	EN 60068-2-6
Damaging gas	EN 60068-2-42
Relative humidity	EN 60068-2-56
Ambient conditions	
Ambient temperature	-20 ... 60 °C (-4 ... 140 °F)
Storage temperature	-25 ... 85 °C (-13 ... 185 °F)
Relative humidity	95 % non-condensing
Shock resistance	shock type I, shock duration 11 ms, shock amplitude 15 g, number of shocks 18
Vibration resistance	frequency range 10 ... 150 Hz; transition frequency: 57.56 Hz, amplitude/acceleration ± 0.075 mm/1 g; 10 cycles frequency range 5 ... 100 Hz; transition frequency: 13.2 Hz amplitude/acceleration ± 1 mm/0.7 g; 90 minutes at each resonance
Damaging gas	designed for operation in environmental conditions acc. to ISA-S71.04-1985, severity level G3
Mechanical specifications	
Degree of protection	IP20 (module) , a separate housing is required acc. to the system description
Connection	via backplane
Mass	approx. 750 g
Dimensions	57 x 107 x 132 mm (2.2 x 4.2 x 5.2 inch)
Data for application in connection with hazardous areas	
EU-Type Examination Certificate	PTB 97 ATEX 1074 U
Marking	Ⓔ II 2(1) G Ex d [ia Ga] IIC Gb
Directive conformity	

Technical Data

Directive 2014/34/EU	EN 60079-0:2009 EN 60079-1:2007 EN 60079-11:2007 EN 60079-26:2007 EN 61241-11:2006
International approvals	
ATEX approval	PTB 97 ATEX 1075
EAC approval	Russia: RU C-IT.MIII06.B.00129
Marine approval	
Lloyd Register	15/20021
DNV GL Marine	TAA0000034
American Bureau of Shipping	T1450280/UN
Bureau Veritas Marine	22449/B0 BV
General information	
System information	The module has to be mounted in appropriate backplanes (FB92**) in Zone 1, 2, or outside hazardous areas. Observe the corresponding EC-type examination certificate.
Supplementary information	EC-Type Examination Certificate, Statement of Conformity, Declaration of Conformity, Attestation of Conformity and instructions have to be observed where applicable. For information see www.pepperl-fuchs.com .

Assembly

Front view

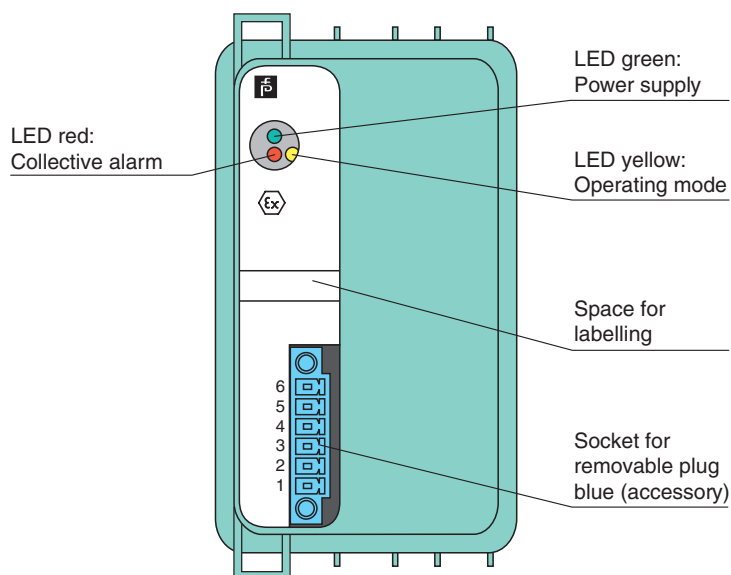

Accessories

	DTM LB/FB	
	FB9224*	Field Unit
	FB9225*	
	FB9248*	

Product Versions

Bus couplers are available with different firmware versions. The type code extension * designates the firmware version.