



Singleturn absolute encoder

AVS58-0

- Industrial standard housing Ø58 mm
- 16 Bit singleturn
- Data transfer up to 2 MBaud
- Optically isolated RS 422 interface
- Servo or clamping flange
- Zero-set function



Function

This singleturn absolute encoder with modern fast technology transmits a position value corresponding to the shaft setting via the SSI interface (Synchronous Serial Interface). The resolution of the AVS58 is maximum 65536 steps per revolution. The devices of the AVS58 series are equipped with a microcontroller. The control module sends a clock bundle to the absolute encoder to obtain position data. The rotary encoder then sends the position data synchronous to the cycles of the control module. It is possible to select the following items with function inputs the counting direction and the zero-set function (preset value). This singleturn absolute encoder is available either in clamp flange design with a shaft diameter of 10 mm x 20 mm or in a servo flange design with a shaft diameter of 6 mm x 10 mm. The electrical connection is made by a 12-pin round plug connector. A version with a 1 m cable connector is also available.

Dimensions

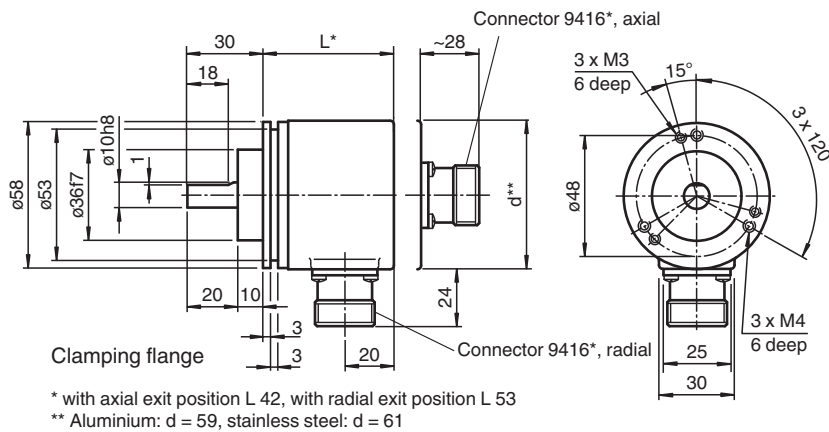

Release date: 2023-02-14 Date of issue: 2023-02-14 Filename: t49168_eng.pdf

Dimensions

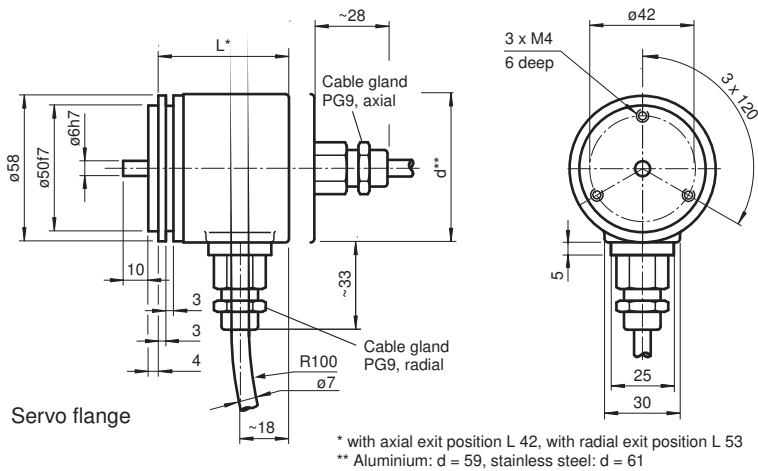
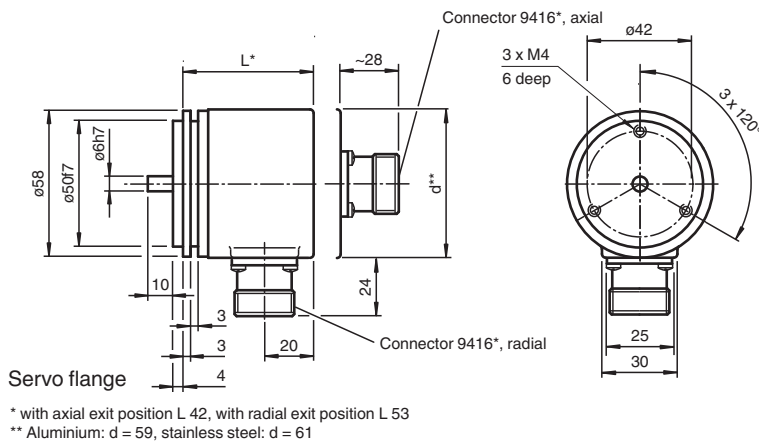
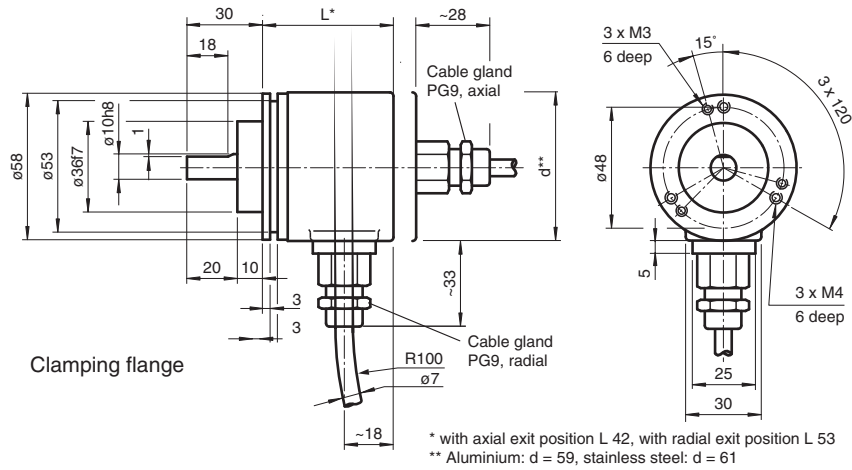

Technical Data

General specifications			
Detection type	photoelectric sampling		
Device type	Singleturn absolute encoder		
Electrical specifications			
Operating voltage	U_B	4.5 ... 30 V DC	
No-load supply current	I_0	max. 180 mA	
Time delay before availability	t_v	< 250 ms	
Linearity	± 2 LSB at 16 Bit, ± 1 LSB at 13 Bit, $\pm 0,5$ LSB at 12 Bit		

Release date: 2023-02-14 Date of issue: 2023-02-14 Filename: t49168_eng.pdf



















Technical Data

Output code	Gray code, binary code
Code course (counting direction)	cw descending (clockwise rotation, code course descending)
Interface	
Interface type	SSI
Monoflop time	20 ± 10 µs
Resolution	
Single turn	up to 16 Bit
Overall resolution	up to 16 Bit
Transfer rate	0.1 ... 2 MBit/s
Voltage drop	U _B - 2.5 V
Standard conformity	RS 422
Input 1	
Input type	Selection of counting direction (cw/ccw)
Signal voltage	
High	4.5 ... 30 V
Low	0 ... 2 V
Input current	< 6 mA
Switch-on delay	< 10 ms
Input 2	
Input type	zero-set (PRESET 1)
Signal voltage	
High	4.5 ... 30 V
Low	0 ... 2 V
Input current	< 6 mA
Signal duration	min. 100 ms
Switch-on delay	< 10 ms
Connection	
Connector	type 9416 (M23), 12-pin, type 9416L (M23), 12-pin
Cable	Ø7 mm, 6 x 2 x 0.14 mm ² , 1 m
Standard conformity	
Degree of protection	DIN EN 60529, IP65 (without shaft seal) ; DIN EN 60529, IP66/IP67 (with shaft seal)
Climatic testing	DIN EN 60068-2-3, no moisture condensation
Emitted interference	DIN EN 61000-6-4
Noise immunity	DIN EN 61000-6-2
Shock resistance	DIN EN 60068-2-27, 100 g, 6 ms
Vibration resistance	DIN EN 60068-2-6, 20 g, 10 ... 2000 Hz
Approvals and certificates	
UL approval	cULus Listed, General Purpose, Class 2 Power Source
Ambient conditions	
Operating temperature	-40 ... 85 °C (-40 ... 185 °F)
Storage temperature	-40 ... 85 °C (-40 ... 185 °F)
Mechanical specifications	
Material	
Combination 1	housing: powder coated aluminum flange: aluminum shaft: stainless steel
Combination 2 (Inox)	housing: stainless steel flange: stainless steel shaft: stainless steel
Mass	approx. 460 g (combination 1) approx. 800 g (combination 2)
Rotational speed	max. 12000 min ⁻¹
Moment of inertia	50 gcm ²
Starting torque	< 5 Ncm
Shaft load	

Technical Data





Axial	40 N
Radial	110 N

Accessories

	9203	Angled flange
	9416	Female cordset
	9310-3	Synchro clamping element
	9300	Mounting bracket for servo flange
	KW-10/10	Helical coupling
	KW-6/10	Helical coupling
	KW-6/6	Helical coupling
	KW-6/8	Helical coupling
	9401 10*10	Spring steel coupling
	9401 10*12	Spring steel coupling
	9401 6*10	Spring steel coupling
	9401 6*6	Spring steel coupling
	9402 6*6	Spring steel coupling
	9404 10*10	Spring disk coupling
	9404 6*6	Spring disk coupling
	9409 10*10	Bellows coupling
	9409 6*10	Bellows coupling
	9409 6*6	Bellows coupling

Release date: 2023-02-14 Date of issue: 2023-02-14 Filename: t49168_eng.pdf

Accessories

	9409 6*8	Bellows coupling
	9410 10*10	Precision coupling
	9410 6*6	Precision coupling
	MBT-36ALS	Spring-loaded mounting bracket with a diameter of 36 mm
	9416-*M-12P-AVM	Female cordset, M23, 12-pin, PVC cable, 8-core

Connection

Signal	Cable Ø7 mm, 12-core	Connector 9416, 12-pin	Connector 9416L, 12-pin	Explanation
GND (encoder)	White	1	1	Power supply
U _b (encoder)	Brown	2	8	Power supply
Clock (+)	Green	3	3	Positive cycle line
Clock (-)	Yellow	4	11	Negative cycle line
Data (+)	Grey	5	2	Positive transmission data
Data (-)	Pink	6	10	Negative transmission data
Reserved	Blue	7	12	Not wired, reserved
V/R	Red	8	5	Input for selection of counting direction
PRESET 1	Black	9	9	zero-setting input
Reserved	Violet	10	4	Not wired, reserved
Reserved	Grey/Pink	11	6	Not wired, reserved
Reserved	Red/Blue	12	7	Not wired, reserved

--	--

Interface

Description

The Synchronous Serial Interface was specially developed for transferring the output data of an absolute encoder to a control device. The control module sends a clock bundle and the absolute encoder responds with the position value. Thus only 4 lines are required for the clock and data, no matter what the resolution of the rotary encoder is. The RS 422 interface is optically isolated from the power supply.

SSI signal course Standard

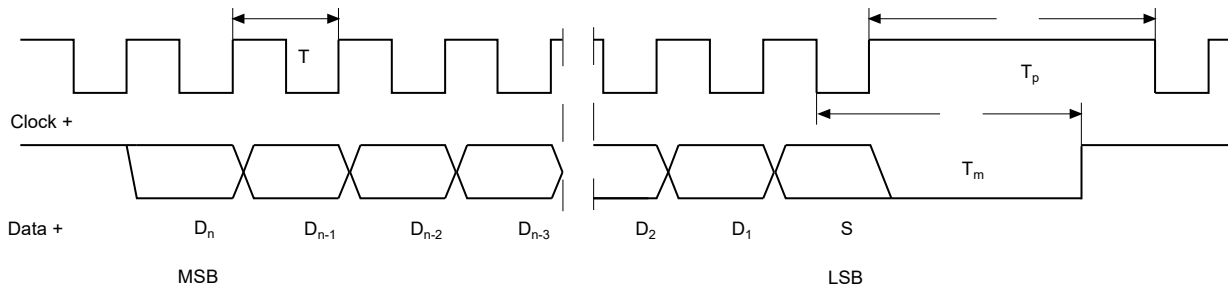

- | | | | |
|--|-----------------------|------------------|--|
| D ₁ , ..., D _n : | Position data | T = 1/f: | Duration of period of clock signal ≤ 1 MHz |
| S: | Special bit | T _m : | Monoflop time 10 μs ... 30 μs |
| MSB: | Most significant bit | T _p : | Clock pause ≥ monoflop time (T _p ≥ T _m) |
| LSB: | Least significant bit | | |

SSI output format Standard

- At idle status signal lines "Data +" and "Clock +" are at high level (5 V).
- The first time the clock signal switches from high to low, the data transfer in which the current information (position data (D_n) and special bit (S)) is stored in the encoder is introduced.
- The highest order bit (MSB) is applied to the serial data output of the encoder with the first rising pulse edge.
- The next successive lower order bit is transferred with each following rising pulse edge.
- After the lowest order bit (LSB) has been transferred the data line switches to low until the monoflop time T_m has expired.
- No subsequent data transfer can be started until the data line switches to high again or the time for the clock pause T_p has expired.
- After the clock sequence is complete, the monoflop time T_m is triggered with the last falling pulse edge.
- The monoflop time T_m determines the lowest transmission frequency.

SSI output format ring slide operation (multiple transmission)

- In ring slide operation, multiple transmission of the same data word over the SSI interface makes it possible to offer the possibility of detecting transmission errors.
- In multiple transmission, 25 bits are transferred per data word in standard format.

Release date: 2023-02-14 Date of issue: 2023-02-14 Filename: t49168_eng.pdf

- If the clock change is not interrupted after the last falling pulse edge, ring slide operation automatically becomes active. This means that the information that was stored at the time of the first clock change is generated again.
- After the first transmission, the 26th pulse controls data repetition. If the 26th pulse follows after an amount of time greater than the monoflop time T_m , a new current data word will be transmitted with the following pulses.



If the pulse line is exchanged, the data word is generated offset. Ring slide operation is possible up to max. 13 bits.

Block diagram

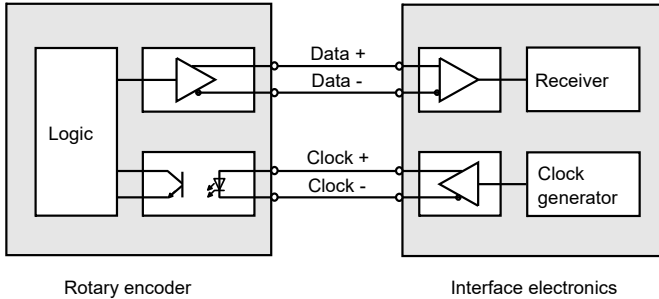

Line length

Line length in m	Baudrate in kHz
< 50	< 400
< 100	< 300
< 200	< 200
< 400	< 100

Inputs

The selection of the counting direction input (cw/ccw) is activated with 0-level. The zero-set input (PRESET 1) is activated with 1-level.

zero-set input (PRESET 1)

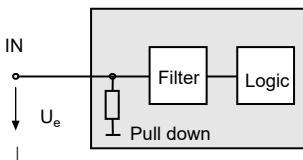

Input for selection of counting direction (cw/ccw)

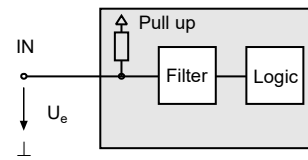

Type Code

Release date: 2023-02-14 Date of issue: 2023-02-14 Filename: t49168_eng.pdf

Order code

A	V	S	5	8	-						0	N	-	0	0		
---	---	---	---	---	---	--	--	--	--	--	---	---	---	---	---	--	--

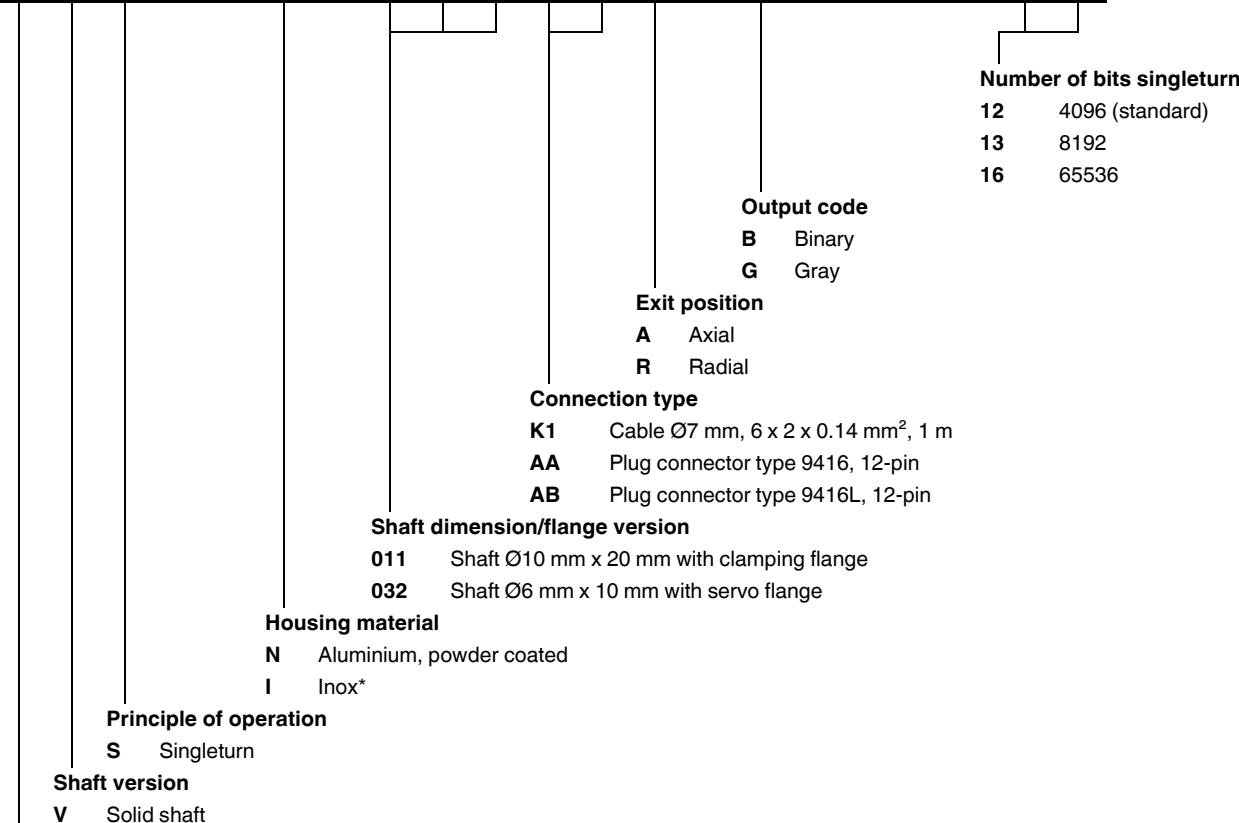

Number of bits singleturn

12	4096 (standard)
13	8192
16	65536

Output code
B Binary
G Gray

Exit position
A Axial
R Radial

Connection type
K1 Cable Ø7 mm, 6 x 2 x 0.14 mm², 1 m
AA Plug connector type 9416, 12-pin
AB Plug connector type 9416L, 12-pin

Shaft dimension/flange version
011 Shaft Ø10 mm x 20 mm with clamping flange
032 Shaft Ø6 mm x 10 mm with servo flange

Housing material
N Aluminium, powder coated
I Inox*

Principle of operation
S Singleturn

Shaft version
V Solid shaft

Data format
A SSI (Synchronous Serial Interface)

*Housing material I only available with axial exit position.

Release date: 2023-02-14 Date of issue: 2023-02-14 Filename: t49168_eng.pdf