



## Multitrurn absolute encoder ASM58-K

- Industrial standard housing  $\varnothing 58$  mm
- 30 Bit multitrurn
- Data transfer up to 2 MBaud
- Optically isolated RS 422 interface
- Recessed hollow shaft
- Zero-set function electrically and by preset key



### Function

This multitrurn absolute encoder with modern fast technology transmits a position value corresponding to the shaft setting via the SSI interface (Synchronous Serial Interface). The maximum resolution of the ASM58-K is maximum 65536 steps per revolution at 16384 revolutions. The devices of the ASM58-K series are equipped with a microcontroller. The control module sends a clock bundle to the absolute encoder to obtain position data. The rotary encoder then sends the position data synchronous to the cycles of the control module. It is possible to select the following items with function inputs the counting direction and the zero-set function (preset value). Another feature of this absolute encoder is the built in preset key at the rear housing side. By means of this, the position value can be locally set to zero. For status and diagnosis indication furthermore it is equipped with 2 LEDs. The absolute encoder is mounted directly onto the application shaft, without any coupling. Rotation of the absolute encoder is prevented by a torque rest. The electrical connection is made by a 12-pin round plug connector. It is also possible to obtain a version with a 1 m cable connector.

### Dimensions

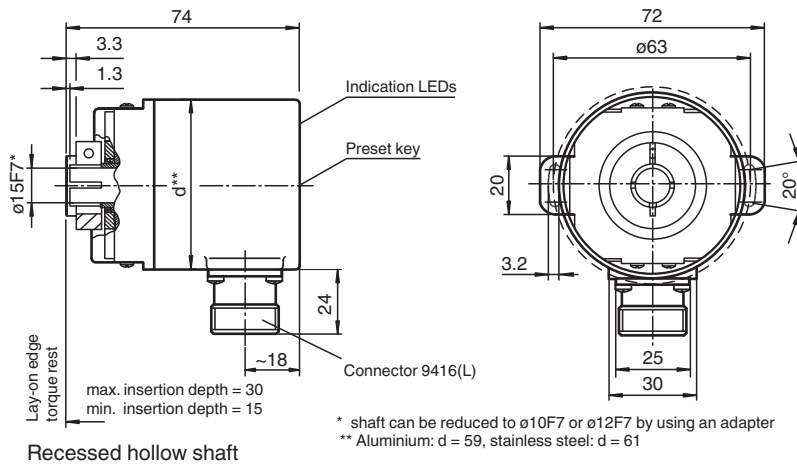

## Dimensions

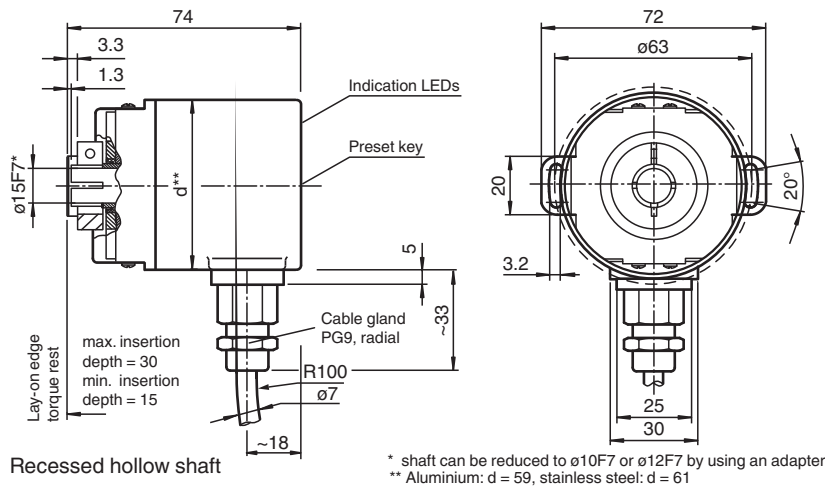

## Technical Data

### General specifications

Detection type	photoelectric sampling
Device type	Multiturn absolute encoder

### Indicators/operating means

LED green	supply voltage/preset key pressed
LED red	internal diagnostic test failed

### Electrical specifications

Operating voltage	$U_B$	4.5 ... 30 V DC
Power consumption	$P_0$	$\leq 1$ W
Time delay before availability	$t_v$	$< 250$ ms
Linearity		$\pm 2$ LSB at 16 Bit, $\pm 1$ LSB at 13 Bit, $\pm 0,5$ LSB at 12 Bit
Output code		Gray code, binary code
Code course (counting direction)		cw descending (clockwise rotation, code course descending)

### Interface

Interface type	SSI
Monoflop time	$20 \pm 10$ $\mu$ s
Resolution	
Single turn	up to 16 Bit
Multiturn	14 Bit
Overall resolution	up to 30 Bit
Transfer rate	0.1 ... 2 MBit/s
Voltage drop	$U_B - 2.5$ V
Standard conformity	RS 422

### Input 1

Input type	Selection of counting direction (cw/ccw)
Signal voltage	
High	4.5 ... 30 V or open input (cw ascending)
Low	0 ... 1 V (cw descending)
Input current	$< 6$ mA
Switch-on delay	$< 10$ ms







### Input 2

Input type	zero-set (PRESET 1)
Signal voltage	
High	4.5 ... 30 V
Low	0 ... 1 V or open input
Input current	$< 6$ mA

## Technical Data

Signal duration	min. 100 ms
Switch-on delay	< 10 ms after falling input flank
<b>Connection</b>	
Connector	type 9416 (M23), 12-pin, type 9416L (M23), 12-pin
Cable	Ø7 mm, 6 x 2 x 0.14 mm <sup>2</sup> , 1 m
<b>Standard conformity</b>	
Degree of protection	DIN EN 60529, IP65 (without shaft seal) ; DIN EN 60529, IP66/IP67 (with shaft seal)
Climatic testing	DIN EN 60068-2-3, no moisture condensation
Emitted interference	DIN EN 61000-6-4
Noise immunity	DIN EN 61000-6-2
Shock resistance	DIN EN 60068-2-27, 100 g, 6 ms
Vibration resistance	DIN EN 60068-2-6, 20 g, 10 ... 2000 Hz
<b>Approvals and certificates</b>	
UL approval	cULus Listed, General Purpose, Class 2 Power Source
<b>Ambient conditions</b>	
Operating temperature	-40 ... 85 °C (-40 ... 185 °F)
Storage temperature	-40 ... 85 °C (-40 ... 185 °F)
<b>Mechanical specifications</b>	
Material	
Combination 1	housing: powder coated aluminum flange: aluminum shaft: stainless steel
Combination 2 (Inox)	housing: stainless steel flange: stainless steel shaft: stainless steel
Mass	approx. 460 g (combination 1) approx. 800 g (combination 2)
Rotational speed	max. 12000 min <sup>-1</sup>
Moment of inertia	≤ 30 gcm <sup>2</sup>
Starting torque	< 3 Ncm (version without shaft seal)
Shaft load	
Angle offset	± 0.9 °
Axial offset	static: ± 0.3 mm, dynamic: ± 0.1 mm
Radial offset	static: ± 0.5 mm, dynamic: ± 0.2 mm

## Accessories

	<b>9416</b>	Female cordset
	<b>9416-*M-12P-AVM</b>	Female cordset, M23, 12-pin, PVC cable, 8-core
	<b>ACC-PACK-ABS-_S_58 Ø15</b>	Accessories set for Ø58 absolut rotary encoder with recessed hollow shaft 15 mm
	<b>ACC-PACK-ABS-_S_58 Ø14</b>	Accessories set for Ø58 absolut rotary encoder with recessed hollow shaft 14 mm
	<b>ACC-PACK-ABS-_S_58 Ø12</b>	Accessories set for Ø58 absolut rotary encoder with recessed hollow shaft 12 mm
	<b>ACC-PACK-ABS-_S_58 Ø10</b>	Accessories set for Ø58 absolut rotary encoder with recessed hollow shaft 10 mm

**Connection**

Signal	Cable Ø7 mm, 12-core	Connector 9416, 12-pin	Connector 9416L, 12-pin	Explanation
GND (encoder)	White	1	1	Power supply
U <sub>b</sub> (encoder)	Brown	2	8	Power supply
Clock (+)	Green	3	3	Positive cycle line
Clock (-)	Yellow	4	11	Negative cycle line
Data (+)	Grey	5	2	Positive transmission data
Data (-)	Pink	6	10	Negative transmission data
Reserved	Blue	7	12	Not wired, reserved
V/R	Red	8	5	Input for selection of counting direction
PRESET 1	Black	9	9	zero-setting input
Reserved	Violet	10	4	Not wired, reserved
Reserved	Grey/Pink	11	6	Not wired, reserved
Reserved	Red/Blue	12	7	Not wired, reserved

--	--

**Interface**

**Description**

The Synchronous Serial Interface was specially developed for transferring the output data of an absolute encoder to a control device. The control module sends a clock bundle and the absolute encoder responds with the position value.

Thus only 4 lines are required for the clock and data, no matter what the resolution of the rotary encoder is. The RS 422 interface is optically isolated from the power supply.

**SSI signal course Standard**

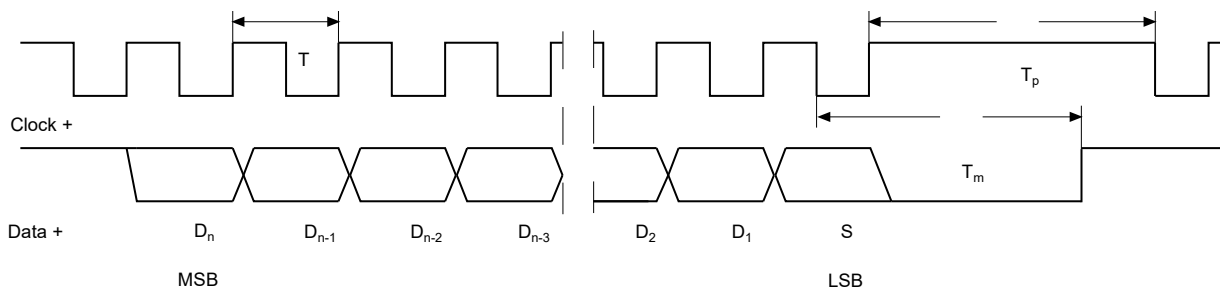

- |  |                       |                  |  |
|--|-----------------------|------------------|--|
| D <sub>1</sub> , ..., D <sub>n</sub> : | Position data         | T = 1/f:         | Duration of period of clock signal ≤ 1 MHz                     |
| S:                                     | Special bit           | T <sub>m</sub> : | Monoflop time 10 μs ... 30 μs                                  |
| MSB:                                   | Most significant bit  | T <sub>p</sub> : | Clock pause ≥ monoflop time (T <sub>p</sub> ≥ T <sub>m</sub> ) |
| LSB:                                   | Least significant bit |                  |  |

**SSI output format Standard**

- At idle status signal lines "Data +" and "Clock +" are at high level (5 V).
- The first time the clock signal switches from high to low, the data transfer in which the current information (position data (D<sub>n</sub>) and special bit (S)) is stored in the encoder is introduced.
- The highest order bit (MSB) is applied to the serial data output of the encoder with the first rising pulse edge.
- The next successive lower order bit is transferred with each following rising pulse edge.
- After the lowest order bit (LSB) has been transferred the data line switches to low until the monoflop time T<sub>m</sub> has expired.
- No subsequent data transfer can be started until the data line switches to high again or the time for the clock pause T<sub>p</sub> has expired.
- After the clock sequence is complete, the monoflop time T<sub>m</sub> is triggered with the last falling pulse edge.
- The monoflop time T<sub>m</sub> determines the lowest transmission frequency.

**SSI output format ring slide operation (multiple transmission)**

- In ring slide operation, multiple transmission of the same data word over the SSI interface makes it possible to offer the possibility of detecting transmission errors.
- In multiple transmission, 25 bits are transferred per data word in standard format.

Release date: 2023-02-14 Date of issue: 2023-02-14 Filename: t49175\_eng.pdf

- If the clock change is not interrupted after the last falling pulse edge, ring slide operation automatically becomes active. This means that the information that was stored at the time of the first clock change is generated again.
- After the first transmission, the 26<sup>th</sup> pulse controls data repetition. If the 26<sup>th</sup> pulse follows after an amount of time greater than the monoflop time  $T_m$ , a new current data word will be transmitted with the following pulses.



If the pulse line is exchanged, the data word is generated offset. Ring slide operation is possible up to max. 13 bits.

**Block diagram**

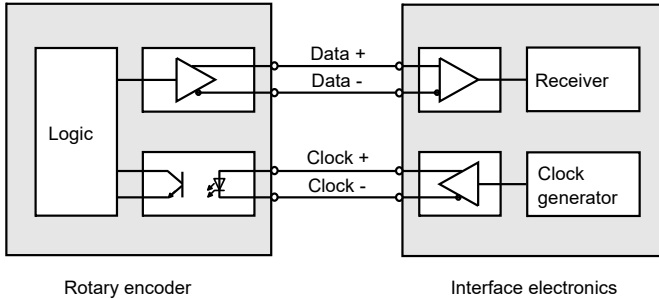

**Line length**

Line length in m	Baudrate in kHz
< 50	< 400
< 100	< 300
< 200	< 200
< 400	< 100

**Operation**

**Inputs**

Input for selection of counting direction (V/R)

Level	counting direction by cw revolution (with view onto the shaft)	Input counting direction (V/R) 
High (input open or connected to +UB)	ascending	
Low (Input connected to GND)	descending	

Zero-set input (Preset)

Level	Funktion	Zero-set input (Preset) 
Low (input open or connected to GND)	Output position value	
High (Input connected to +UB or $U_e > 4,5 V$ )	Activation with falling edge (min. 100 ms)	

**Indicators/operation means**

Preset key	Manually zero setting of the position value.	
LED green	<ul style="list-style-type: none"> <li>• Lights up with supplied encoder</li> <li>• Goes off while preset key is pressed</li> </ul>	
LED red	Alarm/error indication <ul style="list-style-type: none"> <li>• pre-fault indication (data output ist continued)</li> <li>• internal memory error (all data bits are set to high level permanently)</li> </ul>	

**Type Code**

Release date: 2023-02-14 Date of issue: 2023-02-14 Filename: t49175\_eng.pdf

**Order code**

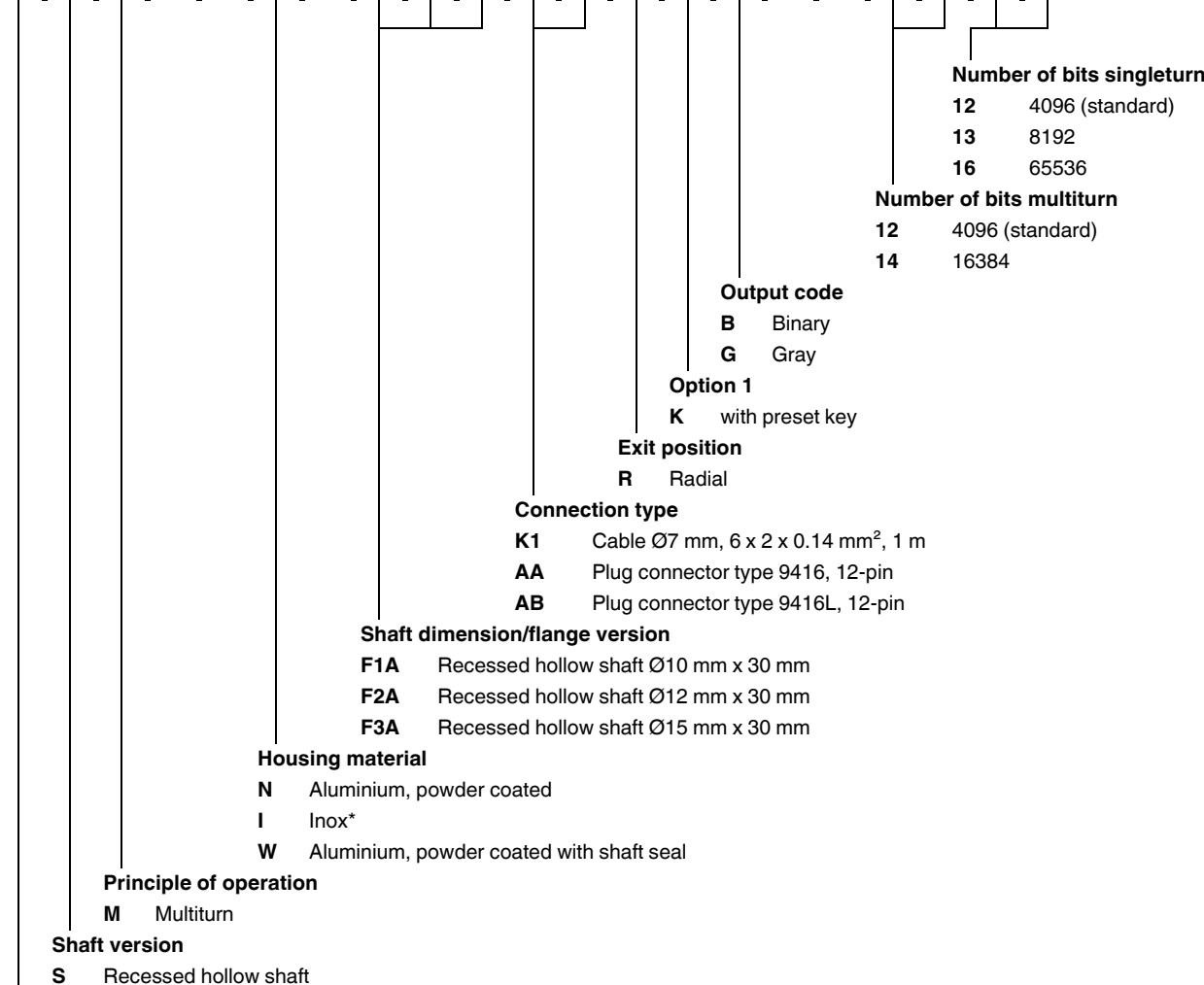

**Data format**

**A** SSI (Synchronous Serial Interface)

\*Housing material I only available with plug connector types.

Release date: 2023-02-14 Date of issue: 2023-02-14 Filename: t49175\_eng.pdf